

### Pumping

- Aggressive, explosive and toxic liquids
- Acids & lyes
- Hydrocarbons
- Heat transfer liquids
- Liquid gases
- Liquids difficult-to-seal
- Ultrapure liquids

### Applications

- Refineries
- Chemical and petrochemical industries
- Refrigeration and heat engineering
- Liquid gas plants
- Galvanic engineering
- Power stations
- Tank installations
- Pharmaceutical industries
- Fibers industries

## HEAVY DUTY HORIZONTAL, SEALLESS CENTRIFUGAL PUMP WITH PERMANENT MAGNET DRIVE SYSTEM, NO MECHANICAL SEAL API 685

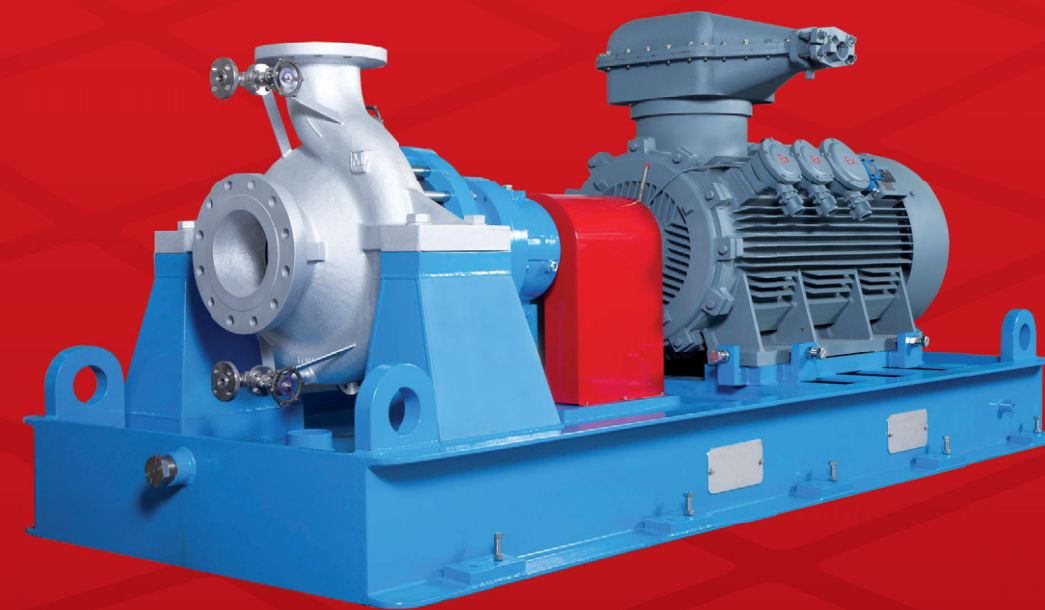

# CN MAG-M API

Manufactured by:



A unit of  
**Mischiatti**  
GROUP

**M PUMPS s.r.l.** - Via dell'Artigianato, 120  
45015 Corbola (Ro) - Italy - [www.mpumps.it](http://www.mpumps.it)  
Tel. +39 0426 346304 - Fax +39 0426 349126

For more information please contact:



### CN MAG-M API Series

The separation of liquid chamber/atmosphere by means of an isolation shell is the best solution to pump aggressive, explosive and toxic liquids, hydrocarbons, heat transfer liquids and liquids difficult to seal.

The hermetic sealless is the perfect answer to the chemical, pharmaceutical, oil & gas and petrochemical industry.

A wide range of pumps covers the different performances.



ISO 14001:2004

273



### General

M PUMPS CN MAG-M Magnetic drive pumps are sealless pumps. The static rear containment shell forms a closed system with hermetically sealed liquid end.

### Applications

M PUMPS CN MAG-M Magnetic drive pumps are designed to improve people and plant safety. Especially when toxic, explosive or other dangerous liquids which react on contact with the atmosphere. For all these services rear containment shell replaces double mechanical seals with external fluid reservoirs and all the required control devices. CN MAG-M pumps offer therefore exceptional benefits to the chemical, petrochemical and allied industries.

Maximum capacity: up to 4000 mc/h, differential head up to 220 m.

Temperature range: from -185 °F (-120 °C) to +662 °F (+350 °C) without external cooling. The maximum allowable working pressure 50bar for the standard version and 150bar for HP Version, higher pressure version available on request up to 842°F (+450°C).

### Leakproof

CN MAG-M pumps have no glands, no seals no valves. Contrary to sealed centrifugal pumps, the hermetic construction of the CN MAG-M mag drive pump ensures a safe and leak free operation. Even under heavy-duty applications the pumps are extremely reliable.

The mag drive pumps have an extended choice of materials as well as a wide variety in models.

With its 100% zero leakage mag drive coupling the M PUMPS mag drives are your problem solvers in fluids and chemicals transfer.

### Construction

M PUMPS CN MAG-M are a single stage volute casing pumps with closed impellers, back-pull-out design, with end suction and top discharge flange.

Centerline legs are provided as standard for foot mounting on the base plate. Capacity and outer dimensions according to API 685 second edition.

### Advantages M PUMPS CN MAG-M mag drive centrifugal pumps

- Zero leakage (100% leak free)
- No mechanical seals or packed glands
- No external flushing systems
- Ensure a clean and safe operating environment, highly efficient
- Increased Mean Time Between Maintenance

### ATEX

M PUMPS CN MAG-M mag drive pumps can be supplied to meet the requirements of Directive 94/9/EC, with ATEX certification II -/2 G cbk II C Tx for installation in potentially explosive atmospheres.

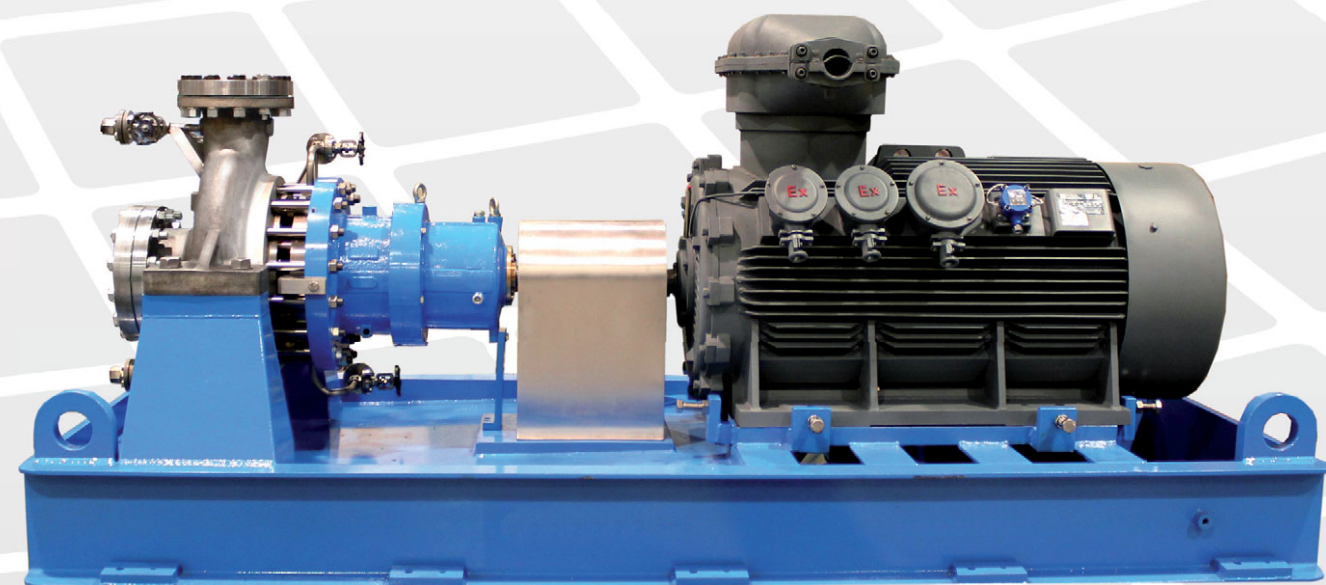
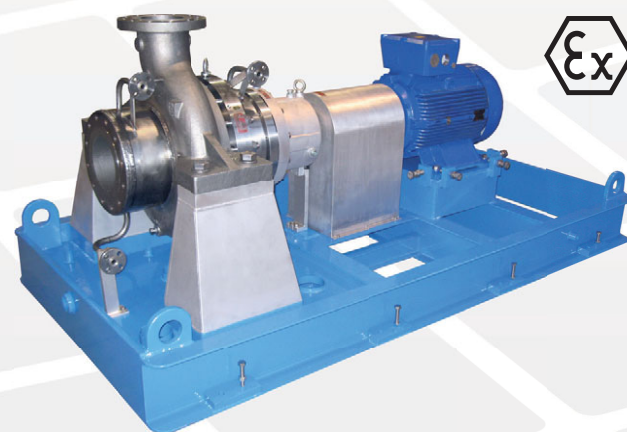

### Performance curves

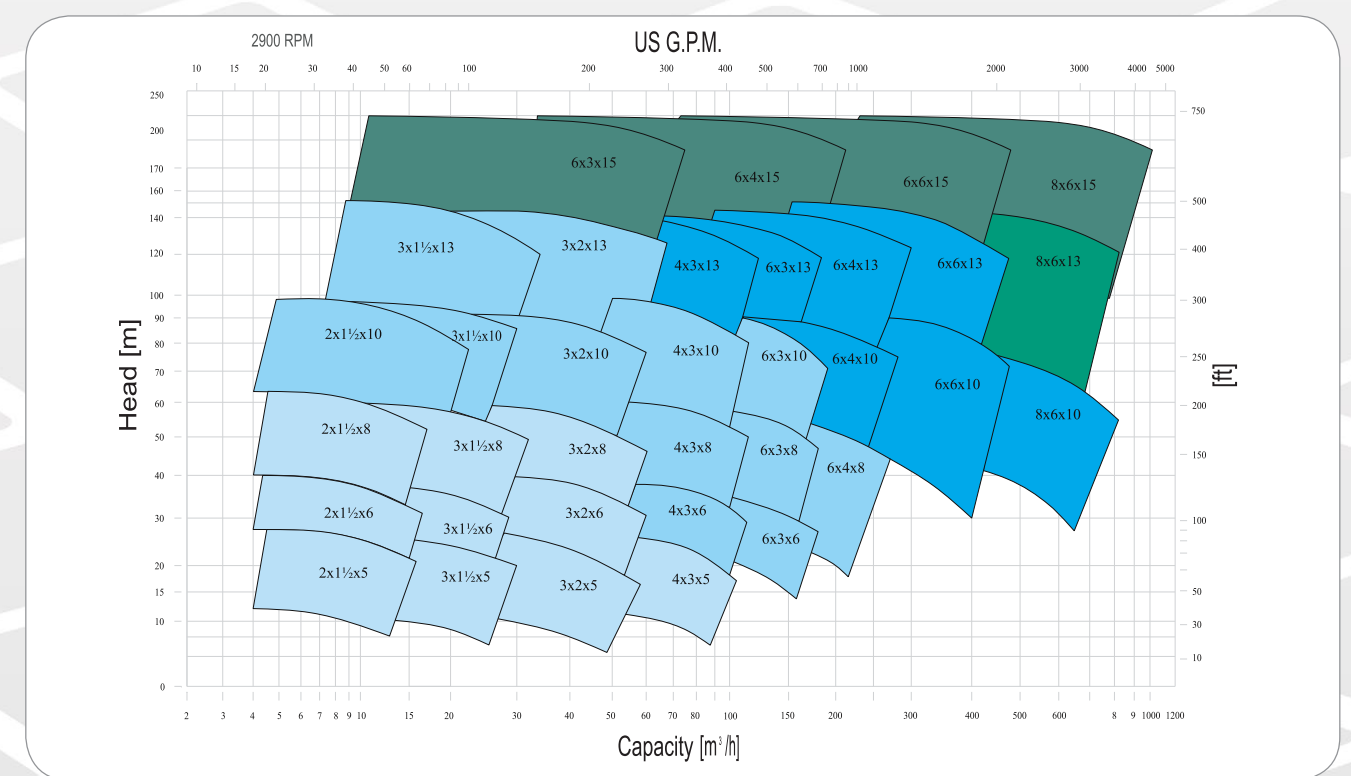
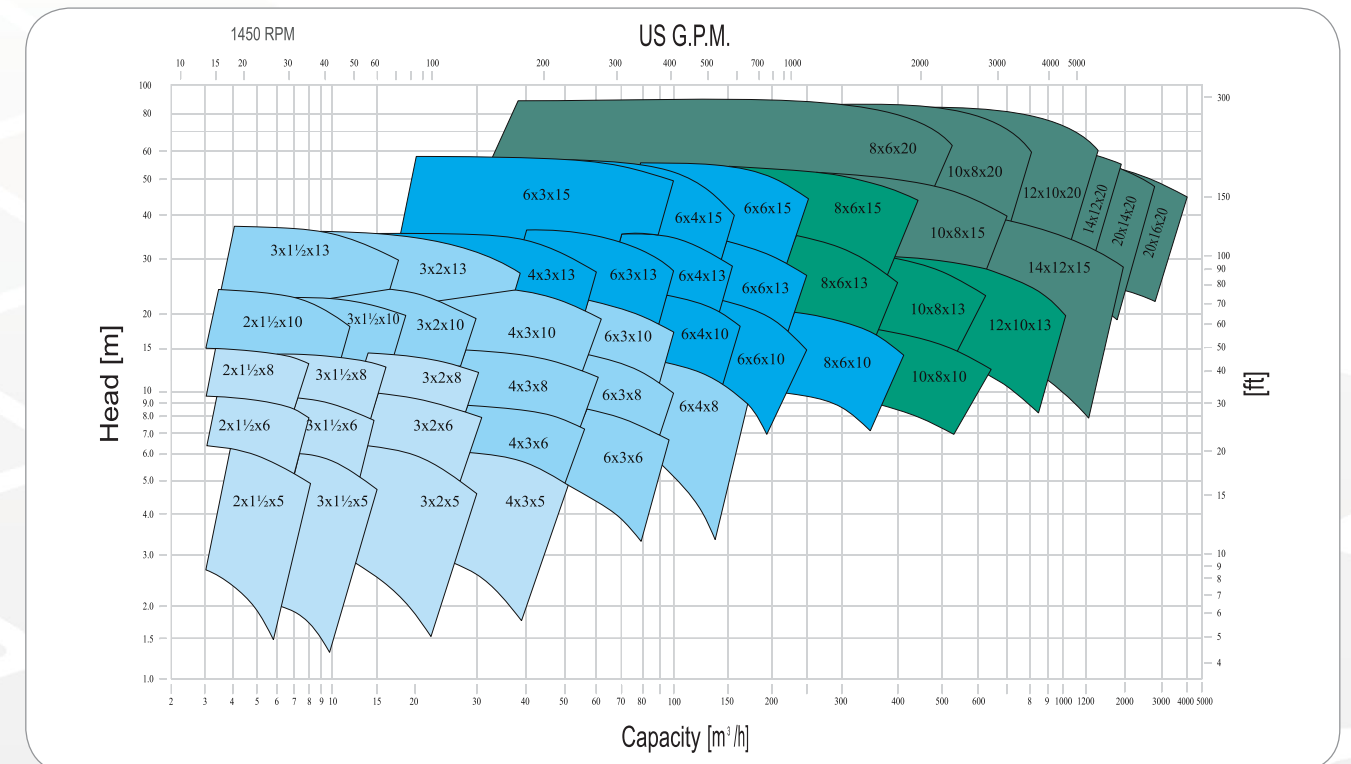

#### Temperature control

Connections for resistant temperature detection elements, liquid and shell surface control are available as standard. Monitoring devices for outer ball bearing are also available on request.

#### Internal circulation, pressurized containment shell area

When the pump is operating, the heat generated in the containment shell and inner magnet area by eddy currents, is dissipated by an internal flow circulation from the discharge directly behind the impeller.

The pressure is increased by the rear impeller back vanes circulation and come back to discharge.

#### Double slide bearings

The shaft is supported by two strong sleeve bearings. The stationary bearings are located centrally in the common bearing housing, which ensure the proper alignment for a true running. Standard material is pure alpha grade - Syntherized Silicon Carbide, highly resistant against corrosion and wear.

The Silicon Carbide parts are elastically mounted by tolerance rings, beared and designed for temperatures up to +662°F (+350 °C) without heat exchanger.

Higher temperature on request.

#### Special Constructions

For critical applications, like extreme low viscosity, or liquids with solid particles, special configurations with intermediate seal are available.

CR MAG-M is the name of this revolutionary pump series. The intermediate seal separates the process fluid from the magnetic cell, that is lubricated by an external flushing circuit.

The external lubrication can be cooled by an additional external cooling system, in this way CR MAG-M pumps can reach very high temperature (up to 842°F [+450°C]).

Jacket version available, in different configuration, for casing, shaft support and bearing support heating, by steam or water.

#### NPSH-Conditions

As the internal circulation from discharge to suction, doesn't rise the temperature in the pumped liquid the handling of boiling liquids is possible without an increase of NPSH-required.

#### Balanced thrust loads

The thrust loads of the closed impellers are totally balanced by back vanes. Minimum residual forces that act in suction flange direction, are beared by strong silicon carbide, spring mounted, thrust bearings.

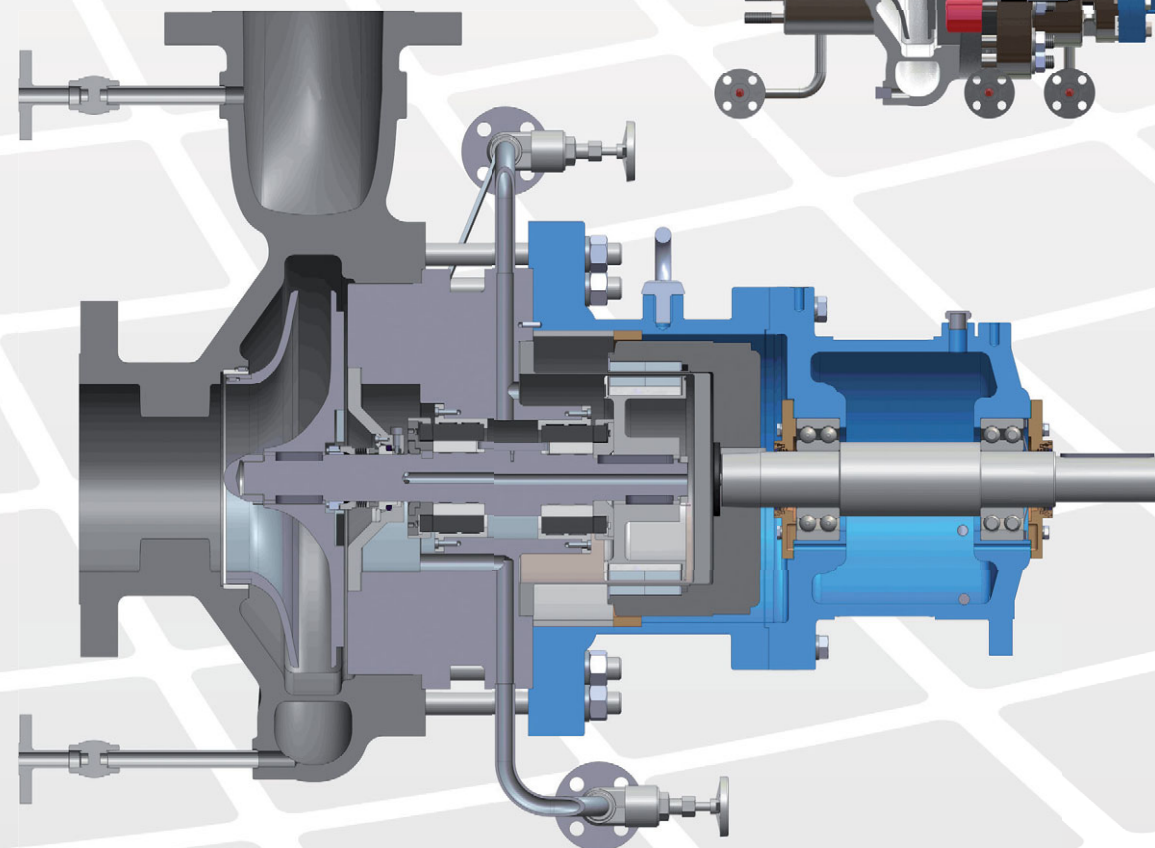

CR MAG-M with secondary containment system API 685 2nd Edition - 3.65 for low viscosity liquids or presence of solids

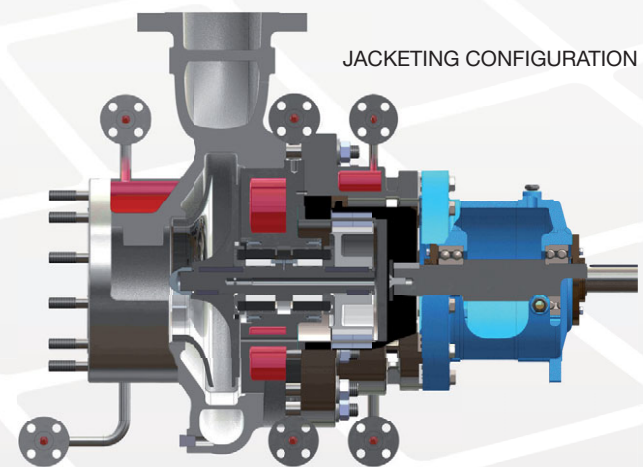

JACKETING CONFIGURATION

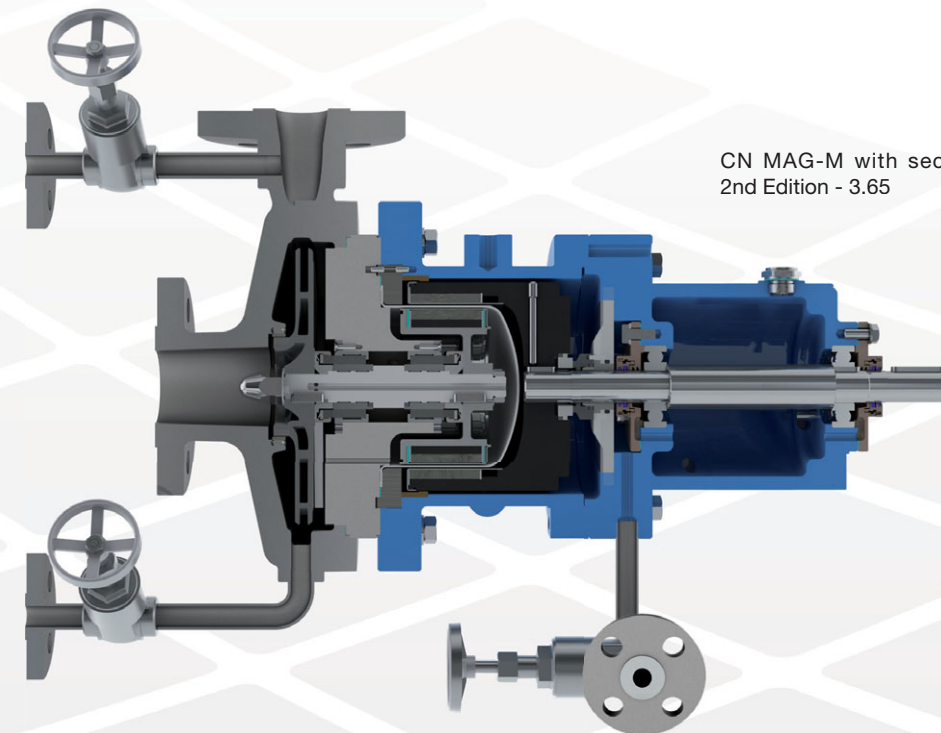

CN MAG-M with secondary containment system API 685 2nd Edition - 3.65

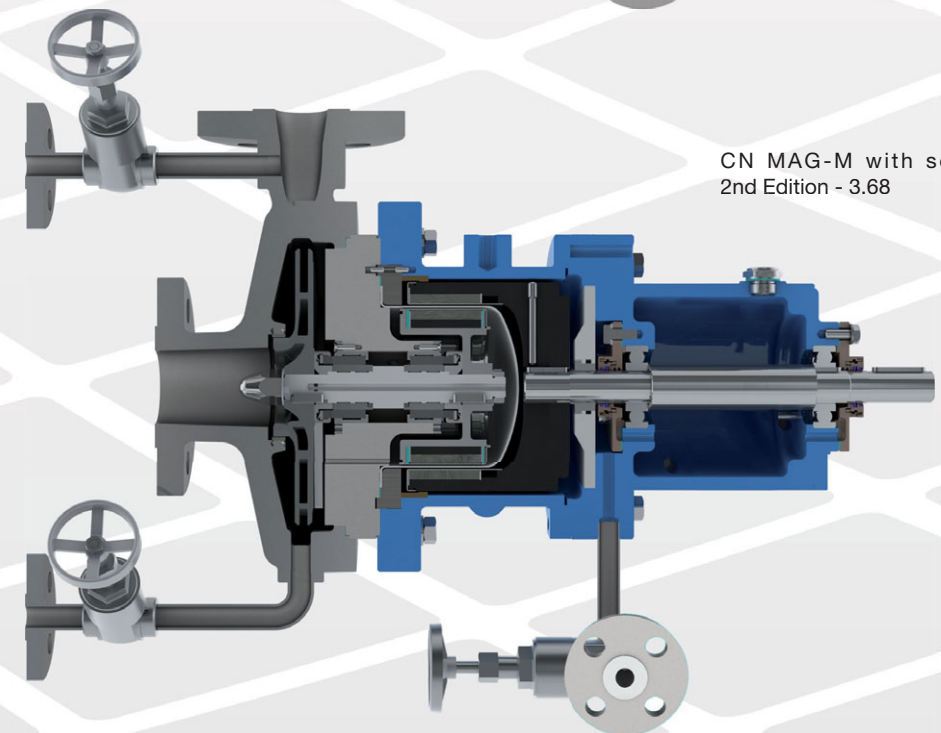

CN MAG-M with secondary control system API 685 2nd Edition - 3.68



FILE NUMBER:  
PD2011A000209

# PUMP DETAILS

Epoxy primer and polyacrylic enamel water-based painting for the best quality resistance linked to the environmental respect.

CF8M Pump Casing & Impeller High quality casting components.

Other materials:  
 - Hastelloy® C276,  
 - Incoloy® 825,  
 - Duplex,  
 - Titanium,  
 - Others materials available on request.



Field assembling of the product lubricated bearing arrangement does not require special tools. The bearing materials available are of three different types to provide the best solution for each application: Silicon Carbide (SSiC), Tungsten Carbide (WC) and Special Carbon. The use of elastic rings reduces the sleeve bearing loads and the thrust bearing loads to a minimum, to guarantee many years of maintenance-free operation.

**RWP QUICK CARTRIDGE KIT** to guarantee an easy and fast maintenance.



Closed impeller statically and dynamically balanced. The axial thrusts are balanced by back vanes, for the best axial balancing independently from suction pressure.

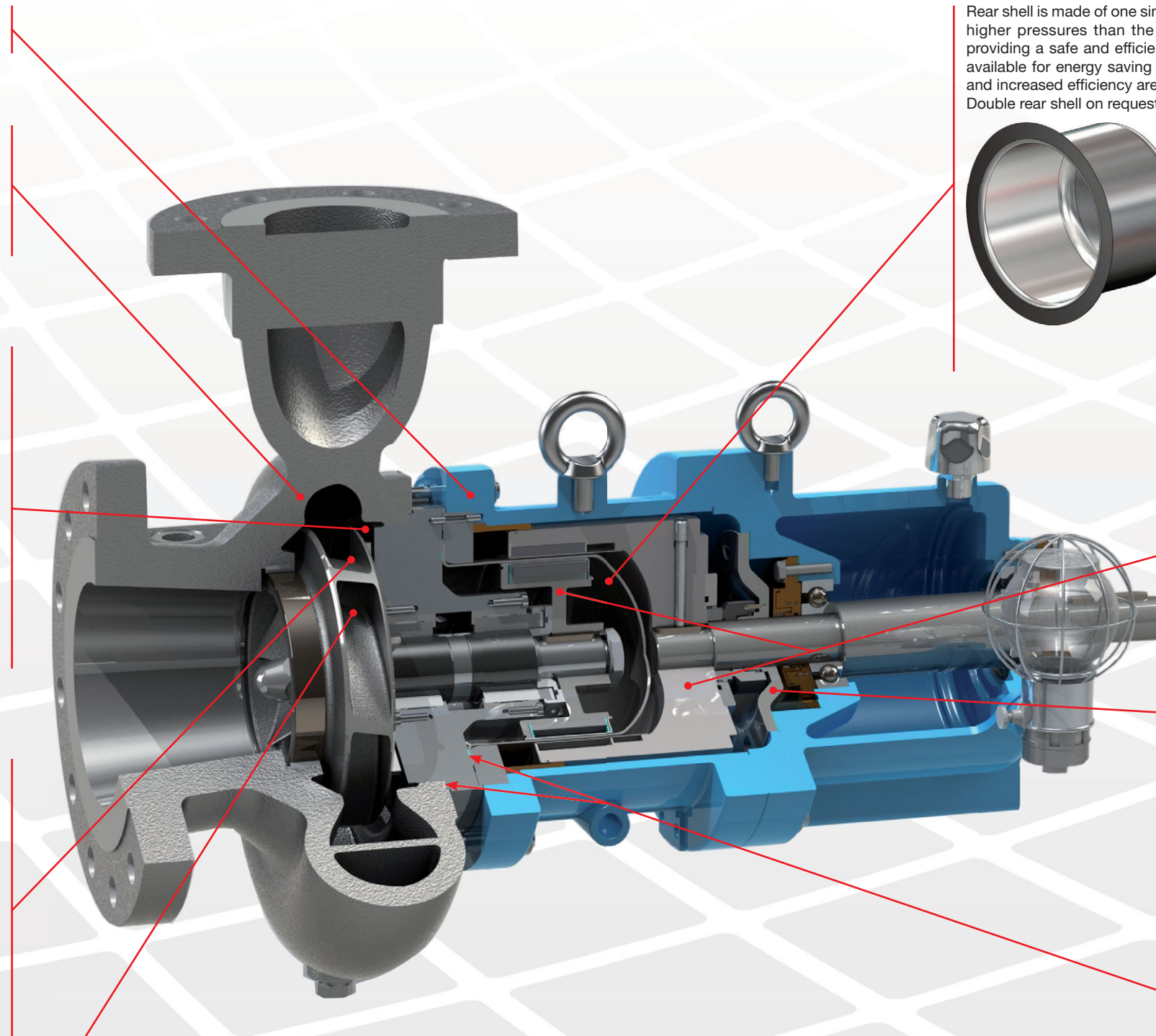

Rear shell is made of one single piece, no welding, ellipsoidal profile that has been studied to withstand higher pressures than the traditional one. Hastelloy® C276 is standard isolation shell material - providing a safe and efficient solution - system pressure max 16 bar. Hybrid rear casing technology available for energy saving configuration. Titanium Alloy is an upgrade when higher pressure ratings and increased efficiency are required. Double rear shell on request.

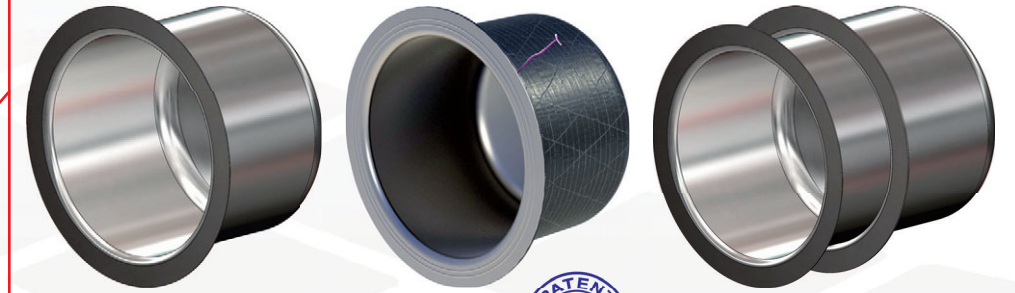

FILE NUMBER:  
PD2010A000249



High power synchronous magnetic coupling designed by our Technical Office and with rare earth magnetic elements mechanically locked. The high performance magnets can operate at liquid temperatures of up to 662 °F (+350 °C) without external cooling. Transmittable horsepower exceeds 520 kW / 700 HP.

Special bare frame design allows the adoption of secondary containment and secondary control systems, in full comply to API 685 latest edition.

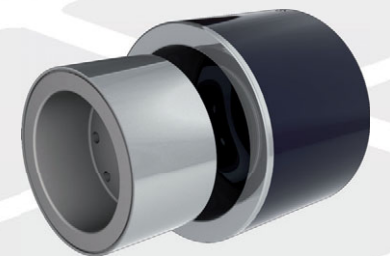

Sealing system with flat gaskets prevents from leaking in the atmosphere - different materials available:

- Asbestos free (standard)
- PTFE
- Graphoil
- GYLON®
- Spyral Wound
- Other on request